

D
E
F

A-
B
C

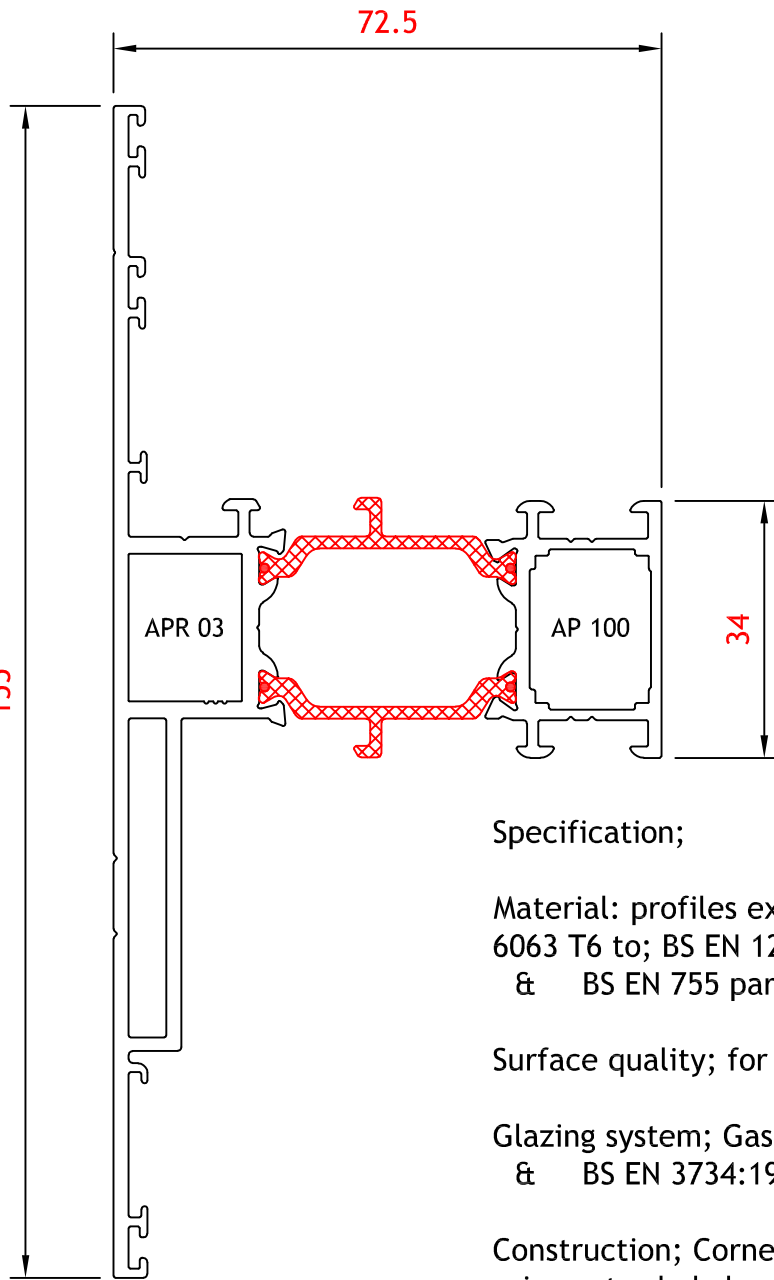

Specification;

Material: profiles extruded from alloy 6063 T6 to; BS EN 12020-2:2008 & BS EN 755 part 1-9:2008

Surface quality; for powder coating

Glazing system; Gaskets to Din 7863 & BS EN 3734:1997

Construction; Corners to be constructed using extruded aluminium cleats 70456 and strengthened/sealed with jointing compound and corner chevrons 63952

Structural Values

Ixx - 92.23 cm⁴
Iyy - 51.36 cm⁴

